

DESCRIPTION OF THE MACHINE

THE MACHINE IS BUILT TO PERFORM ENLARGEMENT AND / OR REDUCTION ENDS OF PIPES, USING SPECIAL RADIAL TOOLS.

IT'S POSSIBLE TO MAKE SLOTS (TORCA SLOTS OR SIMILAR)

BY SPECIAL TOOL (WORK DIAMETER Ø80)

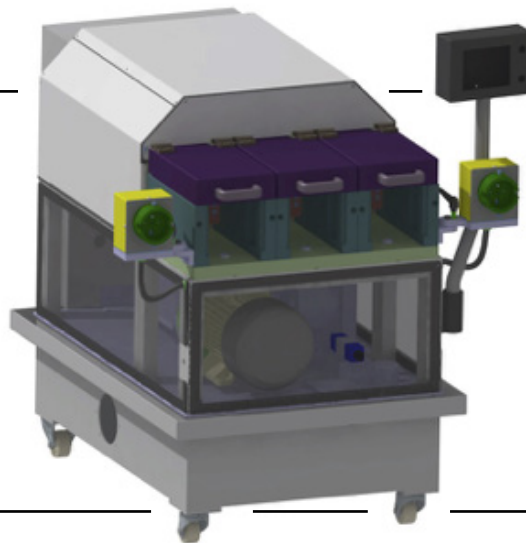

FRAME WITH BUILT-IN HYDRAULIC UNIT
WHEEL KIT FOR MACHINE MOVEMENT
PLC FOR MACHINE CONTROL
PUSH-BUTTON PANEL OR PEDAL BOARD FOR CYCLE START
PROGRAMMING KEYBOARD (TOUCH SCREEN)
ELECTRONIC CONTROL OF WORKING QUOTAS
ELECTRICAL CABINET ON BOARD THE MACHINE
MAGNETIC OR ELECTROMECHANICAL SAFETY SWITCHES
SAFETY COVERS

SLOTTING TOOL (SA)

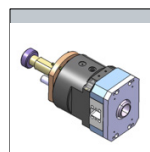

CLAMP TO ENLARGE (C/E)

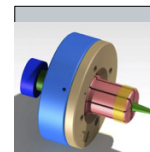

CLAMP TO REDUCE (C/R)

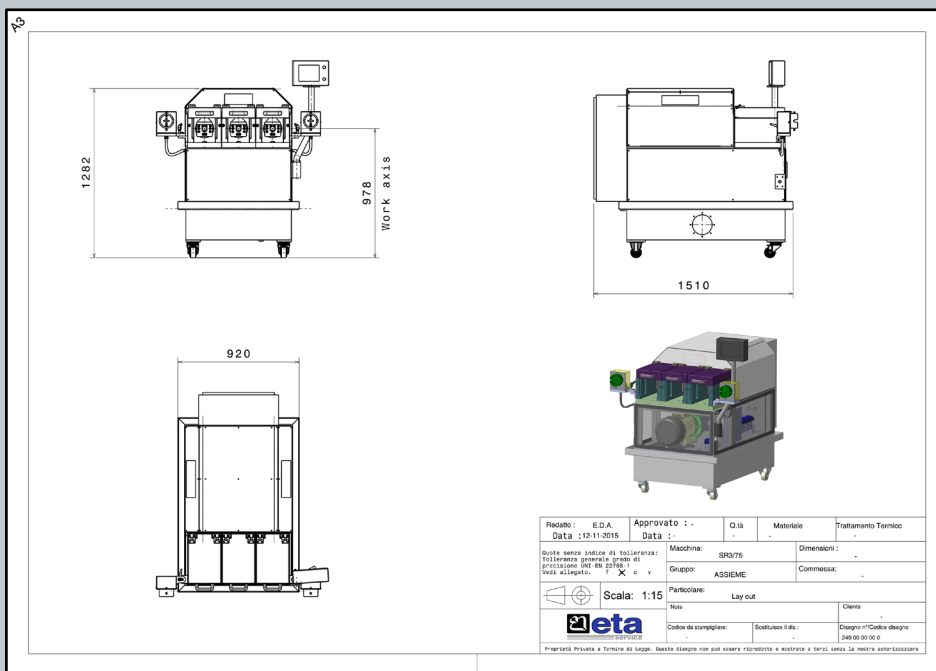
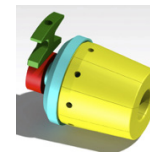

TECHNICAL SPECIFICATIONS

Tension: 400V	Work diameter: 35-80 mm
Frequency: 50Hz	MAX calibration length: 80mm (dependent thickness / diameter)
Auxiliar circuits Tension: 24V	MAX reduction: 8mm single step
Width (mm): 920	MAX enlargement: 8mm single step
Length (mm): 1510	Pipe Thickness MAX: 2.5mm
Height (mm): 1280	Average machine time (sec): 2/5
Weight Kg: 1300	Average set up time (min): 5

OPTIONAL

DESCRIPTION

Hoist	Hoist 200Kg for lifting tools, incorporated in the machine
Front plate	Table incorporated with the machine for blocking positioners
Remote assistance System	Remote assistance system via internet
Objectivation sensors	Connector for piece presence sensor or special cycles.
OK / NOK piece control heads	Plug for conformal piece checking during the work cycle